

Range : Foot-operated taps

Ref : 23100 - PRESTO SOL 509 floor built in

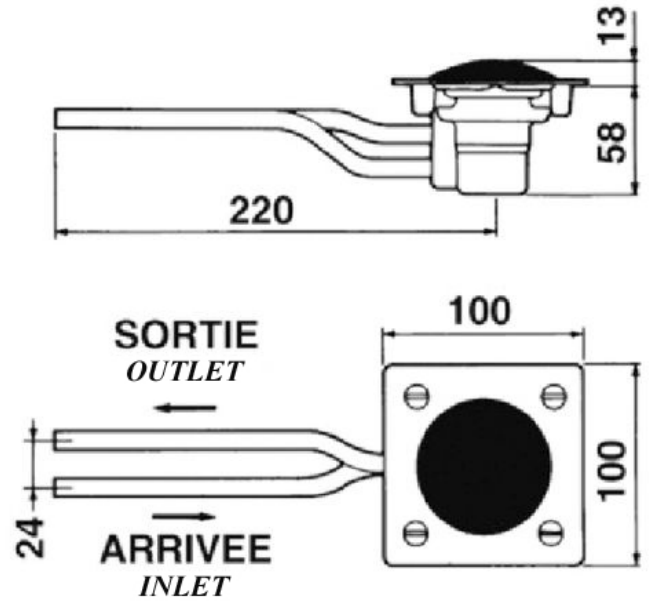

> **Working pressure :**

- 1 to 5 bar

> **Flow :**

- 15L/min at 3 bar, when used alone, 6L/min should it be used with one PRESTO washbasin spout equipped with a water limiter
- Anti-water-hammering design

> **Flow time :**

- 3 to 5 seconds

> **Operation :**

- By pushing on the membrane

> **Hydraulic supply :**

- Water Inlet/outlet 10mm diameter (could be used with cold – hot – mixed temperature water)

> **Material and colour finish :**

- Brass body and components with molded chrome treatment
- Neoprene membrane
- 304L Stainless steel plate (Z2 CN 18 10)

> **Thermal resistance :**

- Resistant to a temperature of 75°C for 30 minute thermal shock

> **Delivered with :**

- Instruction manual

> **Standards & approvals :**

- Brass body in accordance with EN 1982, EN 12164, EN 12156
- Molded chrome-plated body in accordance with EN 12540
- 200-hour neutral salt spray resistant (NSS) in accordance with ISO 9227

This document is not contractual. We reserve the right to modify the characteristics of our products without notice in advance. All our brands and models are registered trade marks.

